

GN 99.8

Clamping nuts with double lever

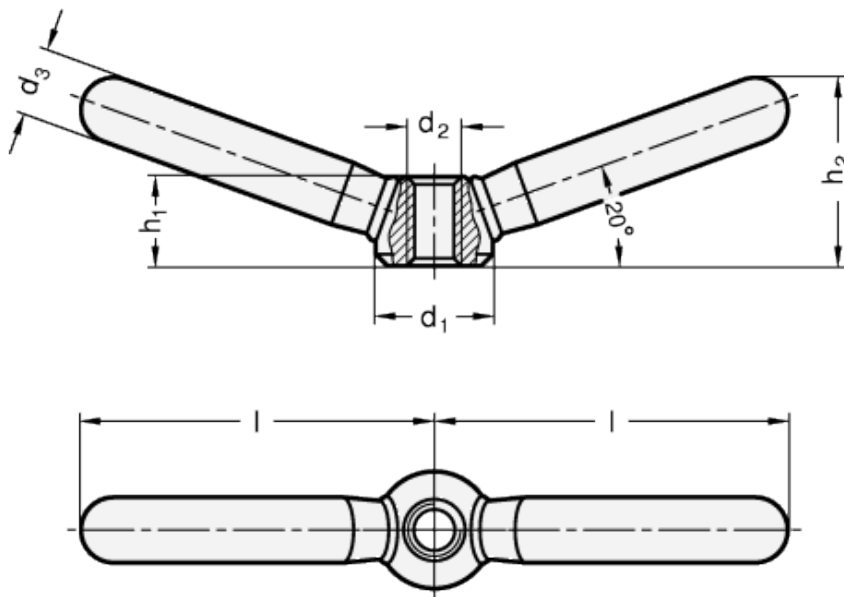

INOX
Stainless Steel



technical informations

Material

AISI 304 stainless steel, sandblasted matte finish. The two lever arms are butt-welded to the hub.

Assembly

Tapped through hole.

Features and applications

AISI 304 stainless steel, thanks to its high resistance to corrosion allows the application of these clamping nuts on machines and equipment in those sectors where laws or particular hygienic, climatic and environmental factors make it mandatory to use corrosion resistant materials.

Standard Elements	Main dimensions				Mounting hole		Weight
Description	d ₁	d ₂	d ₃	h ₁	h ₂ ≈	l ≈	g
GN 99.8-16-M8	16	M8	10	12.5	26	47.5	50
GN 99.8-20-M10	20	M10	12	15	32	59.5	100
GN 99.8-25-M12	25	M12	14	19	40	75.5	212
GN 99.8-32-M16	32	M16	18	25	52	94.5	435
GN 99.8-40-M20	40	M20	20	31	62	118	710



ELESA and GANTER models all rights reserved in accordance with the law. Always mention the source when reproducing our drawings.

STANDARD MACHINE ELEMENTS WORLDWIDE